

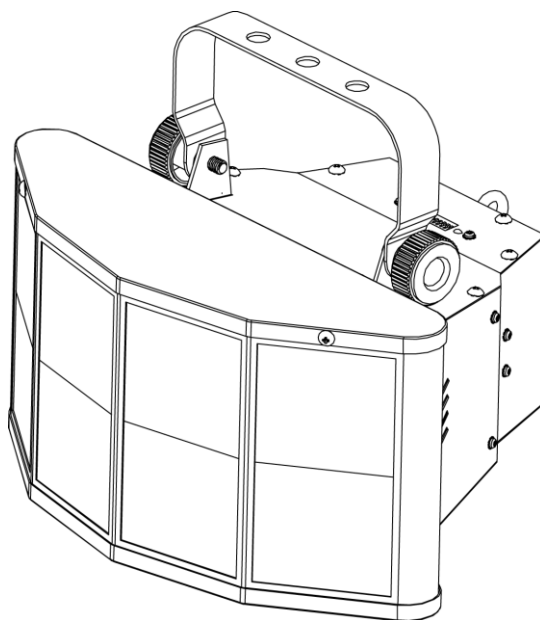

## Snapshot

Use on Dimmer	⊘
Outdoor Use	⊘
Sound Activated	✓
DMX 512	✓
Master/Slave	✓
Autoswitching Power Supply	✓
Replaceable Fuse	✓
User Serviceable	⊘
Duty Cycle	⊘

## User Manual



3000 N 29<sup>th</sup> Ct, Hollywood, FL 33020 U.S.A.  
(800) 762-1084 – (954) 929-1115  
FAX (954) 929-5560  
[www.chauvetlighting.com](http://www.chauvetlighting.com)

# TABLE OF CONTENTS

<b>1. BEFORE YOU BEGIN</b> .....	<b>3</b>
WHAT IS INCLUDED .....	3
UNPACKING INSTRUCTIONS .....	3
SYMBOLS.....	3
AC POWER .....	3
SAFETY INSTRUCTIONS.....	4
<b>2. INTRODUCTION</b> .....	<b>4</b>
FEATURES.....	4
<i>Additional Features</i> .....	4
DMX CHANNEL SUMMARY.....	5
PRODUCT OVERVIEW .....	5
<b>3. SETUP</b> .....	<b>6</b>
FUSE REPLACEMENT .....	6
FIXTURE LINKING.....	6
<i>DMX Data Cable</i> .....	6
<i>Cable Connectors</i> .....	7
<i>3-Pin to 5-Pin Conversion Chart</i> .....	7
<i>Setting up a DMX Serial Data Link</i> .....	7
MASTER/SLAVE FIXTURE LINKING .....	8
MOUNTING .....	8
<i>Orientation</i> .....	8
<i>Rigging</i> .....	8
<b>4. OPERATING INSTRUCTIONS</b> .....	<b>9</b>
OPERATION MODES.....	9
<i>Stand-Alone Mode (Sound-Active, Auto Mode):</i> .....	9
<i>Master/Slave Mode (Master Sound, Master Auto):</i> .....	9
<i>DMX Mode</i> .....	10
USING DMX MODE.....	10
<i>DMX Channel Values</i> .....	10
<i>Setting the Starting Address</i> .....	11
<i>DMX Quick Reference Chart</i> .....	12
GENERAL TROUBLESHOOTING .....	13
CONTACT US.....	14
<b>5. APPENDIX</b> .....	<b>14</b>
DMX PRIMER .....	14
GENERAL MAINTENANCE .....	15
RETURNS PROCEDURE.....	15
CLAIMS.....	15
TECHNICAL SPECIFICATIONS .....	16

# 1. BEFORE YOU BEGIN

## What is included

- 1 x O-Beast™
- 1 x Power Cord
- 1 x Warranty Card
- 1 x User Manual

## Unpacking Instructions

Immediately upon receiving a fixture, carefully unpack the carton, check the contents to ensure that all parts are present, and have arrived in good condition. Notify the shipper immediately and retain the packing material for inspection if any parts appear damaged from shipping or the carton shows signs of mishandling. Save the carton and all packing materials. In the event that a fixture must be returned to the factory, it is important that the fixture be returned in the original factory box and packing.

## Symbols



This paragraph contains critical installation, configuration or operation information. Failure to comply with this information may render the fixture partially or completely inoperative, cause damage to the fixture or cause harm to the operator/user/technician.



This paragraph contains important installation or configuration information. Failure to comply with this information may prevent the fixture from functioning correctly.



This paragraph reminds you of useful, although not critical, information.

## AC Power

This fixture has an auto-switching power supply that can accommodate a wide range of input voltages (100V - 240VAC, 50/60Hz). Before powering on the unit, make sure the line voltage to which you are connecting it is within the range of accepted voltages.



**Always connect the fixture to a switched circuit. Never connect the fixture to a rheostat (variable resistor) or dimmer circuit, even if the rheostat or dimmer channel is used only as a 0% to 100% switch.**

To determine the power requirements for a particular fixture, see the label affixed to the back plate of the fixture or refer to the fixture's specifications chart. A fixture's listed current rating indicates its average current draw under normal conditions.

Before applying power to a fixture, check that the source voltage matches the fixture's requirement. Check the fixture or device carefully to make sure that if a voltage selection switch exists, it is set to the correct line voltage you will use.



**Always connect the fixture to a circuit with a suitable electrical ground.**

# Safety Instructions



**Please read these instructions carefully, which include important information about the installation, usage and maintenance of this product.**

- Please keep this User Guide for future consultation. If you sell the unit to another user, be sure that they also receive this instruction booklet.
- This product is for indoor use only! To prevent risk of fire or shock, do not expose fixture to rain or moisture.
- Make sure there are no flammable materials close to the unit while operating.
- Secure fixture to fastening device using a safety chain.
- Maximum ambient temperature (Ta) is 104°F (40°C). Do not operate the fixture at temperatures higher than this.
- In the event of a serious operating problem, stop using the unit immediately. Never try to repair the fixture by yourself. Repairs carried out by unskilled people can lead to damage or malfunction. Please contact the nearest authorized technical assistance center.
- Make sure the power cord is not crimped or damaged.
- Never disconnect the power cord by pulling or tugging on the cord.
- Avoid direct eye exposure to the light source while it is on.
- Do not daisy chain power to more than 25 units @ 120V.



**There are no user serviceable parts inside the unit. Do not open the housing or attempt any repairs. In the unlikely event that your unit may require service, please contact CHAUVET at 954-929-1115.**

## 2. INTRODUCTION

### Features

- 4-channel DMX-512 LED thick beam derby effect
- Individual control of red, green and blue LEDs (with strobing)
- Motor speed control of back and forth movement
- Built-in automated programs via master/slave or DMX
- Built-in sound activated programs via master/slave or DMX

### Additional Features

- High-power, 3W (600mA) LEDs
- Additional power output: max 25 units @ 120V

# DMX Channel Summary

CHANNEL	FUNCTION
1	Function
2	Strobe
3	Color macro speed
4	Rotation speed

## Product Overview

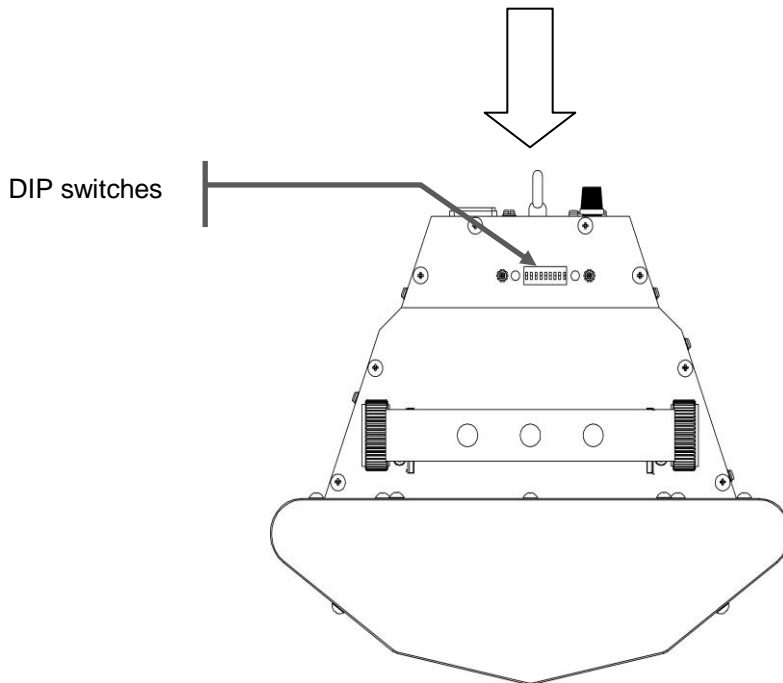
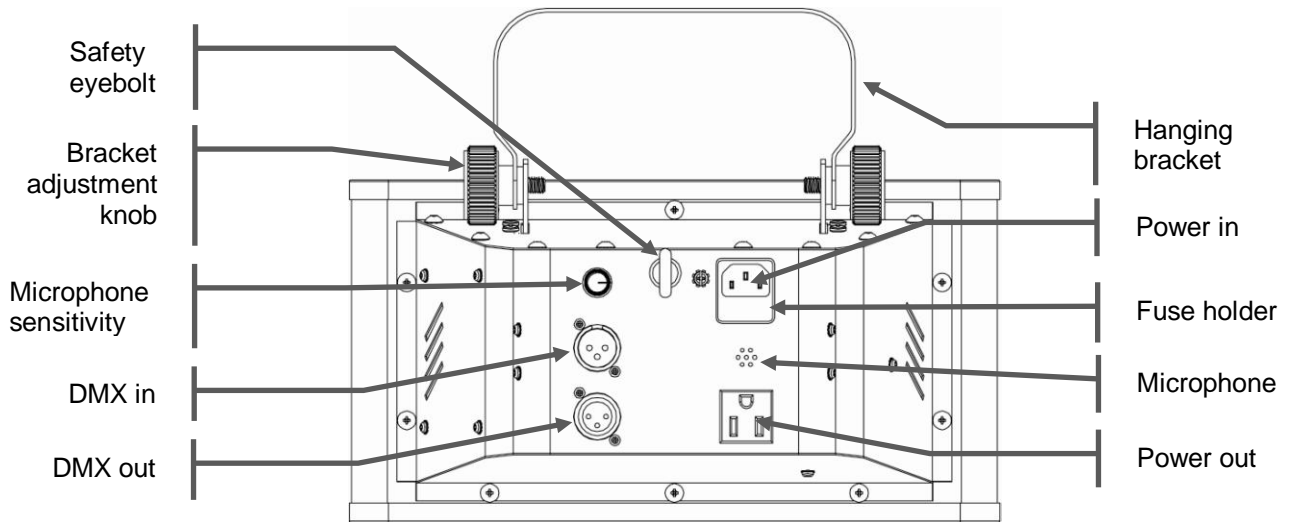

# 3. SETUP

## Fuse Replacement



**Disconnect the power cord before replacing a fuse and always replace with the same type of fuse.**

With a flat head screwdriver, wedge the fuse holder out of its housing. Remove the blown fuse from its holder and replace with the exact same type of fuse. Insert the fuse holder back in its place and reconnect power.

The fuse is located inside this compartment. Remove using a flat head screwdriver.

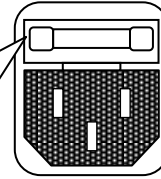

## Fixture Linking

You will need a serial data link to run light shows of one or more fixtures using a DMX-512 controller or to run synchronized shows on two or more fixtures set to a master/slave operating mode. The combined number of channels required by all the fixtures on a serial data link determines the number of fixtures the data link can support.



**Fixtures on a serial data link must be daisy chained in one single line. To comply with the EIA-485 standard no more than 32 devices should be connected on one data link. Connecting more than 32 fixtures on one serial data link without the use of an optically isolated DMX splitter may result in deterioration of the digital DMX signal.**

*Maximum recommended serial data link distance: 500 meters (1640ft.)*

*Maximum recommended number of fixtures on a serial data link: 32*

## DMX Data Cable

To link two or more fixtures together you must use DMX compliant data cables. You can purchase CHAUVET certified DMX cables directly from a dealer/distributor or construct your own cable.

If you choose to create your own cable, please use data-grade cables that can carry a high quality signal and are less prone to electromagnetic interference. Use a Belden© 9841 or equivalent cable, which meets the specifications for EIA RS-485 applications.



**Standard microphone cables cannot transmit DMX data reliably over long distances.**

The cable must have the following characteristics:

*Type: shielded, 2-conductor twisted pair*

*Maximum capacitance between conductors: 30pF/ft.*

*Maximum capacitance between conductor and shield: 55pF/ft.*

*Maximum resistance: 20ohms / 1000ft.*

*Nominal impedance: 100 – 140ohms*

## Cable Connectors

Cabling must have a male XLR connector on one end and a female XLR connector on the other end.

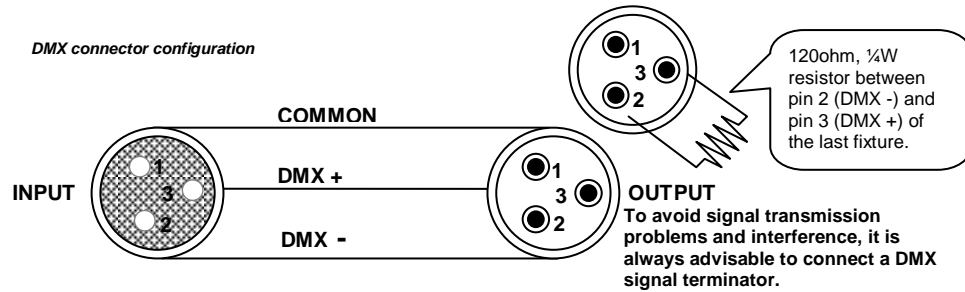

**Do not allow contact between the common and the fixture's chassis ground. Grounding the common can cause a ground loop, and your fixture may perform erratically. Test the cables with an ohmmeter to verify correct polarity and to make sure the pins are not grounded or shorted to each other.**

## 3-Pin to 5-Pin Conversion Chart



**If you use a controller with a 5-pin DMX output connector, you will need to use a 5-pin to 3-pin adapter. You may use the CHAUVET Model number DMX5M, or DMX5F.**

The chart below details the proper cable conversion:

3-PIN TO 5-PIN CONVERSION CHART

Conductor	3-Pin Female (output)	5-Pin Male (Input)
Ground/Shield	Pin 1	Pin 1
Data ( - ) signal	Pin 2	Pin 2
Data ( + ) signal	Pin 3	Pin 3
Do not use		Pin 4
Do not use		Pin 5

## Setting up a DMX Serial Data Link

1. Connect the (male) 3-pin connector of the DMX cable to the output (female) 3-pin connector of the controller.
2. Connect the other end of the cable to the (male) 3-pin input connector of the first fixture
3. Connect the cable from the output of the first fixture to the input of the second fixture.
4. Continue connecting the other features as indicated above.

### CHAUVET Certified DMX Data Cables

Order Code	Description
DMX1.5	DMX Cable 1.5m/4.9ft
DMX4.5	DMX Cable 4.5m/14.8ft
DMX10	DMX Cable 10m/32.8ft

### Universal DMX Controller

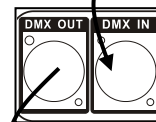
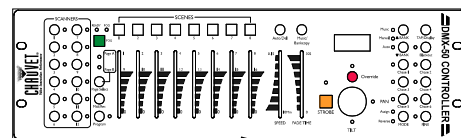

This drawing provides a general illustration of the DMX Input/Output panel of a lighting fixture.

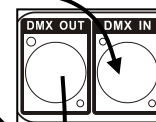

Continue the link

# Master/Slave Fixture Linking

1. Link the fixtures as indicated in steps 1 to 4 of the previous section.
2. The setup of the Master/Slave or Stand-alone operation often requires the first fixture in the chain to be initialized accordingly via settings in the control.
3. In addition, in the Master/Slave mode, the fixtures that follow may also need to be initialized as “slaves.” Please consult the **Operating Instructions** section in this manual for complete instructions for this type of configuration.

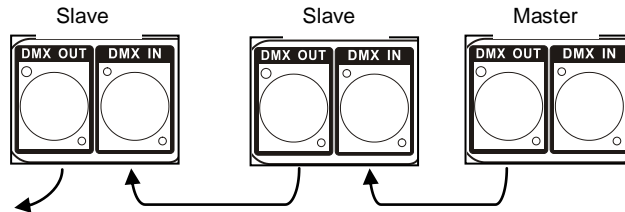

## Mounting

### Orientation

This fixture may be mounted in any safe position.

### Rigging

It is important never to obstruct the vents pathway. Mount the fixture using a suitable “C” or “O” type clamp. Adjust the angle of the fixture by loosening both knobs and tilting the fixture. After finding the desired position, retighten both knobs.

- When selecting an installation location, consider ease of access to the fixture for operation and routine maintenance.
- Always use safety cables.
- Never mount the fixture in places where it may be exposed to rain, high humidity, extreme temperature changes or restricted ventilation.

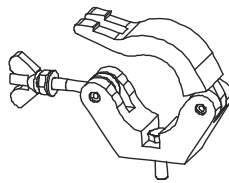

*Hanging Clamp*



**The clamp is sold separately**



# 4. OPERATING INSTRUCTIONS

## Operation Modes

The fixture can be operated as stand-alone, whether sound activated or auto mode, Master/Slave Mode and DMX Mode.

### Stand-Alone Mode (Sound-Active, Auto Mode)

This mode allows a single fixture to run to the beat of the music, or the fixture will change automatically in Auto Mode.

- 1) Set the DIP switches position to Sound Active or Auto Mode.

<b>Mode</b>	<b>DIP switches</b>
Master Auto	1-9 = Off, 10 = On
Master sound-active	1 -8 = Off, 9 = On, 10=Off
Master all on	9-10 = Off, 1-3 = On, 4-8: strobe speed
Master red	2, 3, 9, 10 = Off, 1= On, 4-8: strobe speed
Master green	1, 3, 9, 10 = Off, 2 = On, 4-8: strobe speed
Master blue	1, 2, 9, 10 = Off, 3 = On, 4-8: strobe speed

- 2) The fixture will react to the low frequencies of music via the internal microphone in Sound Active mode, or the fixture will auto change in Auto Mode. In the static color modes, DIP switches 4-8 will control the strobing speed.
- 3) Use the audio sensitivity knob on the back of the fixture to make the fixture more or less sensitive in Sound-Active mode. Turning the knob counterclockwise decreases the sensitivity; turning the knob clockwise increases the sensitivity.
- 4) Combine DIP switches 1-3 to choose multiple color combinations.

### Master/Slave Mode (Master Sound, Master Auto)

This mode will allow you to link up to 32 fixtures together without a controller.

- 1) Use standard DMX cables to daisy chain your fixtures together via the DMX connector on the rear of the fixtures. (For longer cable runs, we suggest a terminator at the output of the last fixture).
- 2) Choose a fixture to function as the Master. Turn DIP switches to the Master position on the fixture. The Master fixture must be the first fixture in line.
- 3) Please see the DIP switches settings for Stand-Alone Mode above to set the fixture to the Master setting of your choice.
- 4) Turn the DIP switches to the Slave position on the Slave fixture, and they will react the same as the Master.

<b>Mode</b>	<b>DIP switches</b>
Slave	1-10 = Off

## DMX Mode

This mode allows the fixture to be controlled by any universal DMX controller.

## Using DMX Mode



If you are unfamiliar with DMX, please read the DMX Primer section.

- 1) Using DMX cables, daisy chain the fixture(s), starting from the output of the DMX controller.
- 2) Assign the individual DMX address, using DIP switches 1 - 9 on each fixture.
- 3) When the fixture detects DMX signal, it will automatically switch to DMX mode.

## DMX Channel Values

CHANNEL	VALUE	FUNCTION
1	000 ⇔ 020	<b>Function</b> Blackout
	021 ⇔ 040	Red
	041 ⇔ 060	Green
	061 ⇔ 080	Blue
	081 ⇔ 100	Red/Green
	101 ⇔ 120	Red/Blue
	121 ⇔ 140	Green/Blue
	141 ⇔ 160	Red/Green/Blue
	161 ⇔ 180	Alternate Red/Green
	181 ⇔ 200	Alternate Red/ Blue
	201 ⇔ 220	Alternate Green/Blue
	221 ⇔ 240	Alternate Red/Green/Blue
	241 ⇔ 255	Sound activation mode (colors & motor rotation/direction)
	2	000 ⇔ 009
010 ⇔ 255		Strobe: (Slow > Fast)
3		<b>Color macro speed (for use when CH.1 is between 161-240):</b>
	000 ⇔ 255	(Slow > Fast)
4	000 ⇔ 255	<b>Rotation speed:</b> (Slow > Fast)

## Setting the Starting Address



If this is your first time addressing a fixture using the DMX-512 control protocol, we suggest you to go to the Appendix Section and read the DMX Primer section. It contains very useful information that will help you understand how DMX works.

Set the starting address using the group of DIP switches located usually on bottom of the fixture. Each DIP switch has an associated value. Adding the value of each switch in the ON position will provide the starting address. The following instructions will help you to figure out which switches to toggle ON given a specific starting address:

- 1) Determine the largest value switch that is less than the starting address. Turn this switch on.
- 2) Subtract the value of the switch you just turned on from the starting address number.
- 3) Determine the largest value switch that is less than the remainder from the previous subtraction. Turn this switch on.
- 4) Subtract the value of the switch you just turned on from the remainder of the previous subtraction.
- 5) Repeat steps three and four until you have a remainder of zero.

### EXAMPLE STARTING ADDRESS

<p><b>Address 10</b></p> <p>Switch # 4 = 8 Switch # 2 = 2 Total = 10</p>	<p>256 128 64 32 16 8 4 2 1</p> <p>9 8 7 6 5 4 3 2 1</p> <p>ON OFF</p>																														
<p><b>Address 24</b></p> <p>Switch # 5 = 16 Switch # 4 = 8 Total = 26</p>	<p>256 128 64 32 16 8 4 2 1</p> <p>9 8 7 6 5 4 3 2 1</p> <p>ON OFF</p>																														
<p><b>Resolving the starting address using simple math.</b></p> <p><b>Address 233</b></p>	<table border="1"> <thead> <tr> <th></th> <th>DIPSWITCH</th> <th>(DMX VALUE)</th> </tr> </thead> <tbody> <tr> <td><math>233 - (128) = 105</math> - Turn ON Dip # 8</td> <td>1</td> <td>1</td> </tr> <tr> <td><math>105 - (64) = 41</math> - Turn ON Dip # 7</td> <td>2</td> <td>2</td> </tr> <tr> <td><math>41 - (32) = 9</math> - Turn ON Dip # 6</td> <td>3</td> <td>4</td> </tr> <tr> <td><math>9 - (8) = 1</math> - Turn ON Dip # 4</td> <td>4</td> <td>8</td> </tr> <tr> <td><math>1 - (1) = 0</math> - Turn ON Dip # 1</td> <td>5</td> <td>16</td> </tr> <tr> <td></td> <td>6</td> <td>32</td> </tr> <tr> <td></td> <td>7</td> <td>64</td> </tr> <tr> <td></td> <td>8</td> <td>128</td> </tr> <tr> <td></td> <td>9</td> <td>256</td> </tr> </tbody> </table>		DIPSWITCH	(DMX VALUE)	$233 - (128) = 105$ - Turn ON Dip # 8	1	1	$105 - (64) = 41$ - Turn ON Dip # 7	2	2	$41 - (32) = 9$ - Turn ON Dip # 6	3	4	$9 - (8) = 1$ - Turn ON Dip # 4	4	8	$1 - (1) = 0$ - Turn ON Dip # 1	5	16		6	32		7	64		8	128		9	256
	DIPSWITCH	(DMX VALUE)																													
$233 - (128) = 105$ - Turn ON Dip # 8	1	1																													
$105 - (64) = 41$ - Turn ON Dip # 7	2	2																													
$41 - (32) = 9$ - Turn ON Dip # 6	3	4																													
$9 - (8) = 1$ - Turn ON Dip # 4	4	8																													
$1 - (1) = 0$ - Turn ON Dip # 1	5	16																													
	6	32																													
	7	64																													
	8	128																													
	9	256																													

# DMX Quick Reference Chart

## DMX Address Quick Reference Chart

Dip Switch Position

DMX DIP SWITCH SET 0=OFF 1=ON X=OFF or ON	#9	0	0	0	0	0	0	0	0	1	1	1	1	1	1	1	1			
	#8	0	0	0	0	1	1	1	1	0	0	0	0	1	1	1	1			
	#7	0	0	1	1	0	0	1	1	0	0	1	1	0	0	1	1			
	#6	0	1	0	1	0	1	0	1	0	1	0	1	0	1	0	1			
Dip Switch Position		DMX Address																		
#1	#2	#3	#4	#5		32	64	96	128	160	192	224	256	288	320	352	384	416	448	480
0	0	0	0	0		32	64	96	128	160	192	224	256	288	320	352	384	416	448	480
1	0	0	0	0	1	33	65	97	129	161	193	225	257	289	321	353	385	417	449	481
0	1	0	0	0	2	34	66	98	130	162	194	226	258	290	322	354	386	418	450	482
1	1	0	0	0	3	35	67	99	131	163	195	227	259	291	323	355	387	419	451	483
0	0	1	0	0	4	36	68	100	132	164	196	228	260	292	324	356	388	420	452	484
1	0	1	0	0	5	37	69	101	133	165	197	229	261	293	325	357	389	421	453	485
0	1	1	0	0	6	38	70	102	134	166	198	230	262	294	326	358	390	422	454	486
1	1	1	0	0	7	39	71	103	135	167	199	231	263	295	327	359	391	423	455	487
0	0	0	1	0	8	40	72	104	136	168	200	232	264	296	328	360	392	424	456	488
1	0	0	1	0	9	41	73	105	137	169	201	233	265	297	329	361	393	425	457	489
0	1	0	1	0	10	42	74	106	138	170	202	234	266	298	330	362	394	426	458	490
1	1	0	1	0	11	43	75	107	139	171	203	235	267	299	331	363	395	427	459	491
0	0	1	1	0	12	44	76	108	140	172	204	236	268	300	332	364	396	428	460	492
1	0	1	1	0	13	45	77	109	141	173	205	237	269	301	333	365	397	429	461	493
0	1	1	1	0	14	46	78	110	142	174	206	238	270	302	334	366	398	430	462	494
1	1	1	1	0	15	47	79	111	143	175	207	239	271	303	335	367	399	431	463	495
0	0	0	0	1	16	48	80	112	144	176	208	240	272	304	336	368	400	432	464	496
1	0	0	0	1	17	49	81	113	145	177	209	241	273	305	337	369	401	433	465	497
0	1	0	0	1	18	50	82	114	146	178	210	242	274	306	338	370	402	434	466	498
1	1	0	0	1	19	51	83	115	147	179	211	243	275	307	339	371	403	435	467	499
0	0	1	0	1	20	52	84	116	148	180	212	244	276	308	340	372	404	436	468	500
1	0	1	0	1	21	53	85	117	149	181	213	245	277	309	341	373	405	437	469	501
0	1	1	0	1	22	54	86	118	150	182	214	246	278	310	342	374	406	438	470	502
1	1	1	0	1	23	55	87	119	151	183	215	247	279	311	343	375	407	439	471	503
0	0	0	1	1	24	56	88	120	152	184	216	248	280	312	344	376	408	440	472	504
1	0	0	1	1	25	57	89	121	153	185	217	249	281	313	345	377	409	441	473	505
0	1	0	1	1	26	58	90	122	154	186	218	250	282	314	346	378	410	442	474	506
1	1	0	1	1	27	59	91	123	155	187	219	251	283	315	347	379	411	443	475	507
0	0	1	1	1	28	60	92	124	156	188	220	252	284	316	348	380	412	444	476	508
1	0	1	1	1	29	61	93	125	157	189	221	253	285	317	349	381	413	445	477	509
0	1	1	1	1	30	62	94	126	158	190	222	254	286	318	350	382	414	446	478	510
1	1	1	1	1	31	63	95	127	159	191	223	255	287	319	351	383	415	447	479	511

## General Troubleshooting

Symptom	Solution(s)	Applies to			
		Lights	Foggers & Snow	Controllers	Dimmers & Chaser
Auto shut off	Check fan thermal switch reset	✓			
Beam is very dim or not bright	Clean optical system or replace lamp Check 220/110 V switch for proper setting	✓			
Breaker/Fuse keeps blowing	Check total load placed on device				✓
Chase is too slow	Check user's manual for speed adjustment	✓		✓	✓
Device has no power	Check for power on Mains. Check device's fuse. (internal and/or external)	✓		✓	✓
Fixture is not responding	Check DMX Dip switch settings for correct addressing Check DMX cables Check polarity switch settings	✓			
Fixture is on but there is no movement to the audio	Make sure you have the correct audio mode on the control switches. If audio provided via 1/4" jack, make sure a live audio signal exists Adjust sound sensitivity knob	✓		✓	✓
Light will not come on after power failure	Some discharge lamps require a cooling off period before the electronics in the fixture can kick start it again. Wait 5 to 10 minutes before powering it up again.	✓			
Loss of signal	Use only DMX cables Install terminator Note: Keep DMX cables separated from power cables or black lights.	✓	✓	✓	✓
Moves slow	Check 220/110V switch for proper setting	✓			
No flash	Re-install bulb; it may have shifted in shipping	✓			
No light output	Check slip ring & brushes for contact Install bulb Call service technician	✓			
Relay will not work	Check reset switch Check cable connections				✓
Remote does not work	Make sure connector is firmly attached to device	✓	✓		

**If you still have a problem after trying the above solutions, please contact CHAUVET Technical Support at the location on the next page.**

# Contact Us

## World Wide

### General Information

CHAUVET  
3000 North 29<sup>th</sup> Court  
Hollywood, FL 33020  
voice: 954.929.1115  
fax: 954.929.5560  
toll free: 800.762.1084

### Technical Support

CHAUVET  
3000 North 29<sup>th</sup> Court  
Hollywood, FL 33020  
voice: 954.929.1115 **(Press 4)**  
fax: 954.929.5560 **(Attention: Service)**

### World Wide Web

[www.chauvetlighting.com](http://www.chauvetlighting.com)

## 5. APPENDIX

### DMX Primer

The DMX mode enables the use of a universal DMX controller device. There are 512 channels in a DMX-512 connection. Channels may be assigned in any manner. A fixture capable of receiving DMX 512 will require access to one or more sequential channels. To do this, each fixture requires a "start address" from 1 to 512. A fixture requiring one or more channels for control begins to read the data on the channel indicated by the start address. For example, a fixture that uses six DMX channels and was addressed to start on DMX channel 100, would read data from channels: 100, 101, 102, 103, 104, and 105.

The user must assign a starting address on the fixture that indicates the first channel reserved in the controller. There are many different types of DMX controllable fixtures and they all may vary in the total number of channels required. Choosing a start address should be planned in advance. Channels should never overlap. If they do, this will result in erratic operation of the fixtures whose starting address are set incorrectly. However, you can control multiple fixtures of the same type using the same starting address as long as the intended result is that of unison movement or operation. In other words, the fixtures will be slaved together and they will all respond in exactly the same way.

DMX fixtures are designed to receive data through a serial DMX Daisy Chain. In a Daisy Chain, the DATA OUT of one fixture connects to the DATA IN of the next fixture. The order in which the fixtures are connected is not important and has no effect on how a controller communicates to each fixture. Use an order that provides for the easiest and most direct cabling, however.

Connect the fixtures using a shielded, two-conductor twisted pair cable with one 3-pin XLR male connector on one end and a 3-pin XLR female connector on the other end. The shield connection is pin 1, while pin 2 is Data Negative (S-) and pin 3 is Data positive (S+). See page 6 for details on this type of cable.



**CHAUVET carries 3-pin XLR DMX compliant cables, DMX-10 (33'), DMX-4.5 (15') and DMX-1.5 (5')**

## General Maintenance

To maintain optimum performance and minimize wear, fixtures should be cleaned frequently. Usage and environment are contributing factors in determining the cleaning frequency. As a general rule, fixtures should be cleaned at least twice a month. Dust build up reduces light output performance and can cause overheating. This can lead to reduced lamp life and increased mechanical wear. Be sure to power off fixture before conducting maintenance.

Unplug fixture from power. Use a vacuum or air compressor and a soft brush to remove dust collected on external vents and internal components. Clean all glass surfaces when the fixture is cold with a mild solution of glass cleaner or Isopropyl Alcohol and a soft lint-free cotton cloth or lens tissue. Apply solution to the cloth or tissue and drag dirt and grime to the outside of the lens. Gently polish optical surfaces until they are free of haze and lint.

The cleaning of internal and external optical lenses and/or mirrors must be carried out periodically to optimize light output. Cleaning frequency depends on the environment in which the fixture operates: damp, smoky or particularly dirty surrounding can cause greater accumulation of dirt on the unit's optics. Clean with soft cloth using normal glass cleaning fluid. Always dry the parts carefully. Clean the external optics at least every 20 days. Clean the internal optics at least every 30/60 days.

## Returns Procedure

Returned merchandise must be sent prepaid and in the original packing; call tags will not be issued. Package must be clearly labeled with a Return Merchandise Authorization Number (RMA #). Products returned without an RMA # will be refused. Call CHAUVET and request an RMA #, prior to shipping the fixture. Be prepared to provide the model number, serial number and a brief description of the cause for the return. Be sure to properly pack fixture; any shipping damage resulting from inadequate packaging is the customer's responsibility. As a suggestion, proper UPS packing or double-boxing is always a safe method to use. CHAUVET reserves the right to use its own discretion to repair or replace product(s).



**Once you have received the RMA#, please include the following information on a piece of paper inside the box:**

- 1) Your name
- 2) Your address
- 3) Your phone number
- 4) The RMA #
- 5) A brief description of the symptoms

## Claims

Damage incurred in shipping is the responsibility of the shipper; therefore, any damage must be reported to the carrier upon receipt of merchandise. It is the customer's responsibility to notify and submit claims with the shipper in the event that a fixture is damaged during shipping. Any other claim for items such as missing component/part, damage not related to shipping, and concealed damage must be made within seven (7) days of receiving merchandise.

# Technical Specifications

## WEIGHT & DIMENSIONS

Length ..... 13in (329mm)  
Width ..... 11.4in (290mm)  
Height ..... 11in (280mm)  
Weight ..... 6.1lbs (2.7kg)

## POWER

Autoswitching ..... 100-240VAC 50/60Hz  
Fuse ..... F2A 250V (5 x 20 mm fast-blow)  
Power Consumption ..... 13W (0.1A) max @ 120V  
Inrush Current ..... (0.2A) @ 120V  
Power Output ..... 25 units max @ 120VAC, 40 units max @ 230V

## LIGHT SOURCE

LED ..... 3 x 3W 600mA (1 Red, 1 Green, 1 Blue) 50,000hrs

## COVERAGE

Coverage angle (horizontal spread) ..... 115°

## THERMAL

Maximum ambient temperature ..... 104°F (40°C)

## CONTROL & PROGRAMMING

Data input ..... locking 3-pin XLR male socket  
Data output ..... locking 3-pin XLR female socket  
Data pin configuration ..... pin 1 shield, pin 2 (-), pin 3 (+)  
Protocols ..... DMX-512 USITT  
DMX Channels ..... 4

## ORDERING INFORMATION

O-Beast™ ..... OBEAST

## WARRANTY INFORMATION

Warranty ..... 2-year limited warranty